



Name: _____

Roll # : _____

Score: _____

Signature: _____

Date: _____

Inverting Amplifier and Close Loop Frequency Response

OBJECTIVE:

- To understand the operation of Op-Amp as an Inverting amplifier.
- Observe the close loop frequency response of the inverting amplifier.
- To determine the max: operating frequency.

EQUIPMENTS:

- Oscilloscope.
- Function generator.
- DC power supply ($\pm 12V$).
- Digital Multimeter.
- Breed board
- Connecting wires.
- Op-Amp I.C 741.
- Few Resistors

THEORY DISCUSSION:

The operational amplifier (abbreviated as Op-amp) is a device that has all the properties required for dc amplification. It contains several stages and circuitry for temperature drift compensation. The gain of the amplifier is far in excess of that available using single transistor. Although it could be made using discrete transistors it is usually an integrated circuit (IC) with all the components on a single silicon chip. This makes operational amplifiers available in large quantities at very low cost.

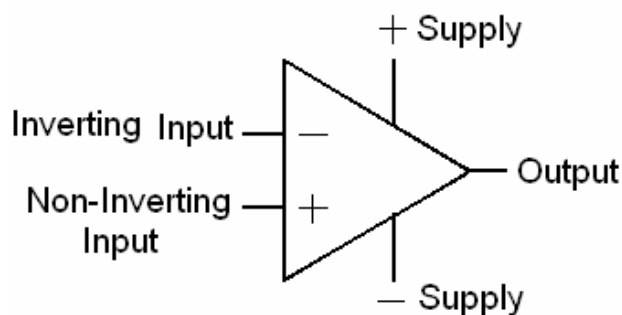

Circuit Symbol for an OP-Amp

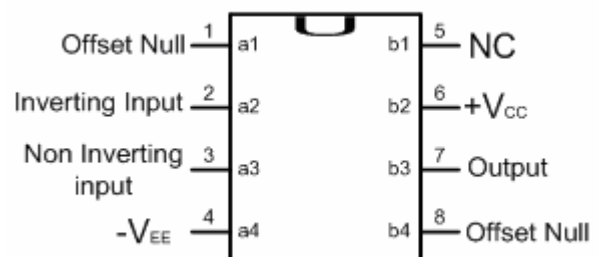

Op-Amp IC 741

Figure # 01(a), shows the circuit symbol for an operational amplifier. We can see some important features:



1. It has positive and negative power connections. This is so that the output can swing either side of zero volts.
2. It has positive and negative inputs, also known as Non inverting and inverting inputs. The signals applied to the positive input appear same on output while signals applied to negative input are inverted at output. Both inputs have same total gain.
3. Although it is not shown on the symbol, the amplifier gain is very high – 100,000 would be a typical value.

As the gain of the op-amp is very high, for a very small input the output saturates equal to the values of DC supplies. The gain can be controlled by negative feedback (i.e. driving a fraction of output to the inverting or negative input). The negative input will now have a different signal on it than the actual input voltage (the sum of the input and the negative feedback). Thus we must have to separate the real input from the inverting input. This can be done by a resistor.

INVERTING AMPLIFIER:

An op-amp connected as an inverting amplifier with a controlled amount of voltage gain is shown in figure # 02,

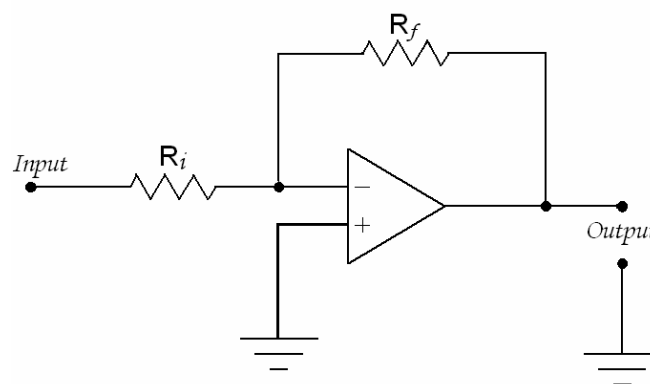

The input signal is applied through a series input resistor (R_i), to the inverting input. Also, the output is fed back through R_f , to the inverting output. The non inverting input is grounded. As the input is applied to the inverting input, output will be inverted form of input. The gain of the amplifier can be controlled be the value of R_f and R_i .

$$A = - \frac{R_f}{R_i} \dots\dots\dots(1)$$

SLEW RATE:

The maximum rate of change of output voltage when a step input voltage is applied to op-amp. Mostly for op-amps $0.5V/\mu sec$ is a typical value of slew rate. Slew rate is also used to determine the max: operating frequency of an op-amp.

$$f_{max} = \frac{Slew\ Rate}{2\pi V_p} \dots\dots\dots(2)$$



From the equation(2) it is clear that as the operating frequency increases the output voltage will decrease and vice versa. This means that;

- To operate op-amp for large signals the input frequency should be decreased.
- To operate op-amp at higher frequencies the output (gain) should be decreased.

PROCEDURE:

1. Wire the circuit shown as in figure # 02.
2. First apply a 1V dc input.
3. Observe the output polarity and measure its value.
4. Calculated the gain, and observe whether the equation 1 is satisfied or not.
5. Now apply a sinusoidal signal of 2V/1KHz peak signal.
6. Observe the output, and again compare measured gain with equation 1.

RESULTS AND OBSERVATION:

R_f	R_i	V_{in}	V_{out}	Calculated gain $-(R_f/R_i)$	Measured gain V_{out}/V_{in}	f_{max}	
						Calculated	Measured



Review Question

Q # 01. What is an Inverting Amplifier?

Ans: _____

Q # 02. Why we use two (positive and negative) DC supplies?

Ans: _____

Q # 03. Can an OP-Amp be used for DC amplification? Why?

Ans: _____

Q # 04. What is negative feedback and how it is achieved in Op-Amps?

Ans: _____

CONCLUSION:

